

Ball Bearing Slides

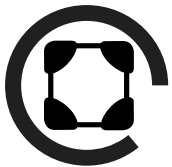

Key Lock



Corner Protection

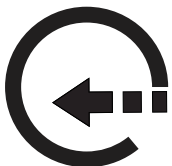

Firm Close Drawers



Edition : 1.0
Date: (12/24)

Instruction Manual

INDUSTRIAL SERIES ROLLER CABINET TIS-263

Order Code: (T6851)

INDUSTRIAL SERIES

BEFORE ASSEMBLING

Please read this instruction manual before assembly.



CAUTION

Before assembly please pay attention to the following points in priority;

Confirmation of components: Before assembling, please confirm all parts arrived and are in good order.

Site for assembly: Please assemble it on the soft floor such as smooth carpet and flannel blanket. When you assemble on wooden floor, please put thin towels on the floor.

Points for attention when assembling: Please wear gloves to ensure that it can be assembled safely, and use two persons to help in the assembly process.

SAFETY INFORMATION

1. Do not pull this roller cabinet, push it when moving.
2. Engage both brakes when this roller cabinet is not being moved. This prevents the roller cabinet rolling away.
3. Secure this roller cabinet properly before moving with a forklift.
4. Do not tow this roller cabinet with power equipment.
5. Do not alter this roller cabinet in any manner. For Example. Do not weld external lock bars or attach electrical equipment.
6. Before locking the roller cabinet, ensure the drawers are completely closed in order for the lock bars to work properly.



CAUTION: Do not attach or mount this product to a vehicle. This may cause personal injury or product damage. Mounting this product to any vehicle in any manner will void warranty.



CAUTION: Keep the product on level surfaces. The product may become unstable and tip if stored or moved on an un-level surface, which may cause personal injury or product damage.



CAUTION: Do not stand on this product. You may fall which may cause personal injury or product damage.



CAUTION: Lock the drawers before moving this product. The drawers could come open and make the product unstable and tip, which may cause personal or product damage.



CAUTION: Be careful when opening more than one drawer. The product may become unstable and tip, which may cause personal injury or product damage.



ROLLER CABINET



INDUSTRIAL SERIES

SPECIFICATIONS

Overall size: 699 x 458 x 845mm (LxWxH)
Overall with casters: 699 x 458 x 993mm (LxWxH)
Package size: 769 x 520 x 920mm (LxWxH)

5x small drawers: 570 x 406 x 75mm
(30kg Per Drawer)
2x large drawers: 570 x 406 x 154mm
(30kg Per Drawer)

Nett Weight: 60.5kg

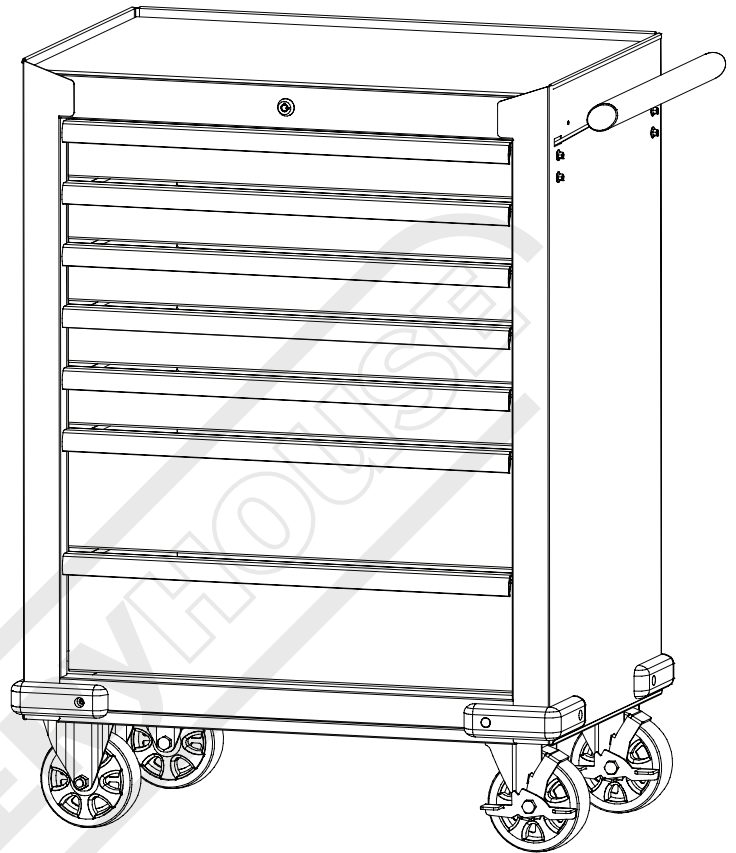

Fixed Wheels (x2)

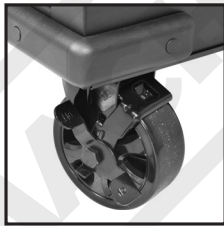

Swivel Brake
Wheels (x2)



Trolley Handle
(x1)



Keys (x2)

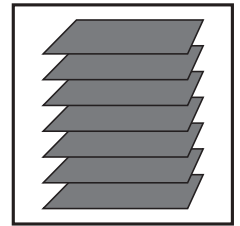

Drawer Liners
(x7)



M8x15mm
Bolts, Washers &
Spring Washers
(x16)



M6x16mm Bolts
(x4)

ASSEMBLY INSTRUCTIONS

TOOLS & ASSISTANCE NEEDED



10 & 13mm spanner/socket

*Tools not included

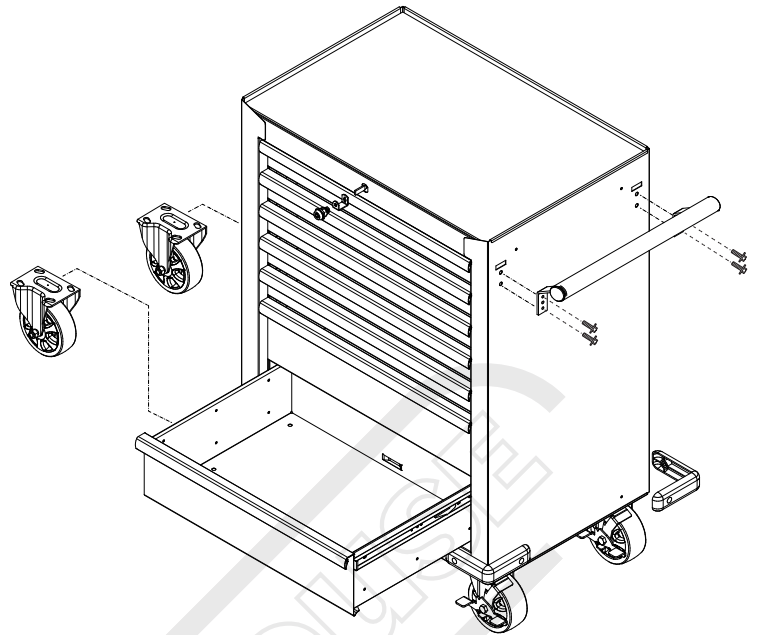

STEP 1.

Handle Installation

- Position the side handle in-line with the holes on the left or right side of the roller cabinet.
- Attach with 4x M6x16mm bolts and tighten with a 10mm spanner/socket as shown in Fig. 1.

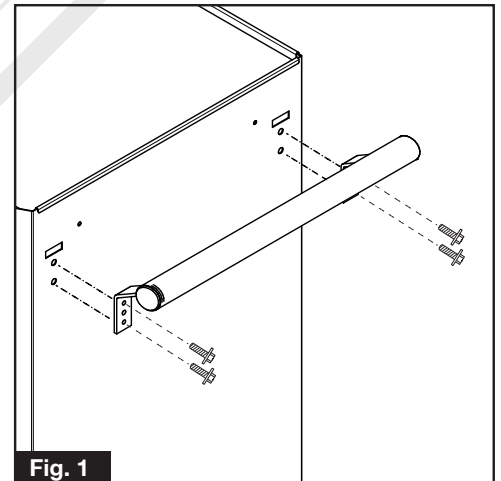

STEP 2.

Attaching the Wheels

- Be sure the drawers are locked and lay the cabinet on its top. Use packaging material or a blanket to protect the finish of the roller cabinet.
- Attach the swivel brake wheels to the base of the roller cabinet on the same side as the handle, using M8x15mm bolts, washers and spring washers as shown in Fig. 2. Tighten using a 13mm spanner/socket.
- Repeat this process for the fixed wheels on the opposite side of the roller cabinet.
- Return the roller cabinet to its upright position.

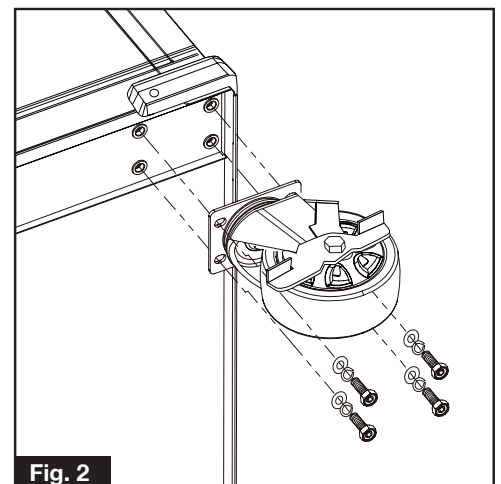

OPERATION

1.

Removing the drawers

- Fully extend the empty drawer.
- Push up the one release lever while pulling down on the other release lever.
- Pull the drawer outward until it is released from the drawer slide.

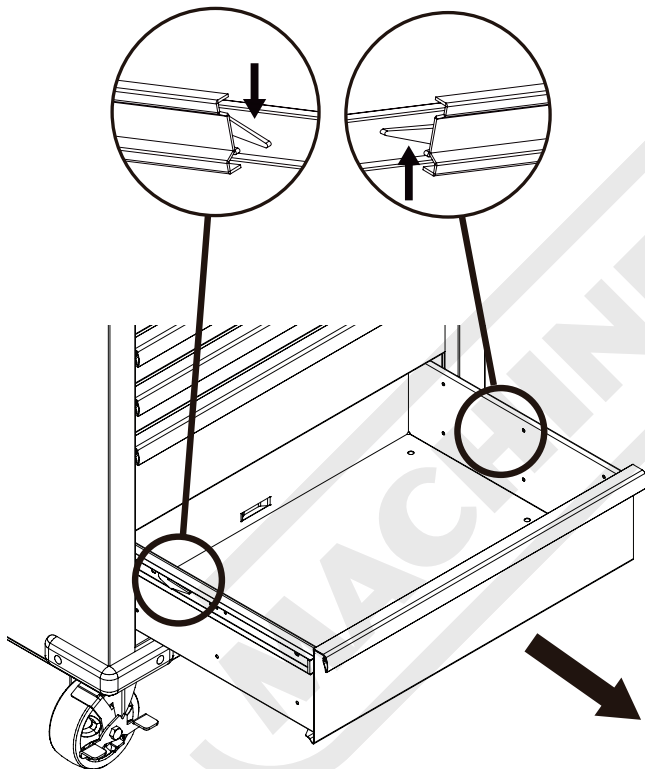

2.

Re-inserting the drawers

- Extend the drawer slides.
- Insert the brackets on each side of the drawer into the slots in the slides, being careful that they are properly positioned.
- Once properly inserted, completely close the drawer to set the slides in their proper positions and make sure you go all the way in to engage the firm close drawer system.

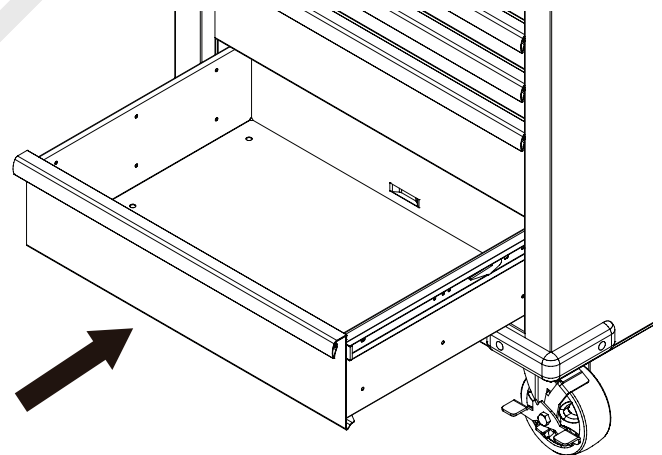

MAINTENANCE

1. Wheel maintenance: Grease the wheels annually using high-quality bearing grease.
2. Drawer maintenance: Lubricate the slides semi-annually with high-quality bearing grease.
3. Lubricate the lock with graphite annually.



ENVIRONMENT PROTECTION

Recycle unwanted materials instead of disposing of them as waste. All tools, accessories and packaging should be sorted, taken to a recycling centre and disposed of in a manner which is compatible with the environment. When the product becomes completely unserviceable and requires disposal, drain any fluids (if applicable) into approved containers and dispose of the product and fluids according to local regulations.

Imported by

HARE & FORBES
MACHINERYHOUSE

Australian Distributor

Hare & Forbes
Machineryhouse
Sydney - Melbourne
Adelaide - Brisbane - Perth

Ph: 1300 202 200
www.machineryhouse.com.au

MACHINERYHOUSE

New Zealand Distributor

Machineryhouse
Auckland
Christchurch

Ph: 0800 142 326
www.machineryhouse.co.nz